

MASSIVE TITANIUM SUBLIMATION PUMPING IN THE CESR INTERACTION REGION* †

N.B. Mistry, R. Kersevan and Yulin Li,
Laboratory of Nuclear Studies, Cornell University, Ithaca, NY 14853 USA

*Abstract**

The residual gas pressure within 30 m of the interaction point (IP) at the e^\pm collider CESR is maintained in the low nanotorr range despite the high gas loads produced by the intense flux of synchrotron radiation from the electron and positron beams. A low pressure is necessary in order to minimize the experimental backgrounds due to beam gas scattering. Within 12 m of the IP, the vacuum chambers incorporate large pumping plenums with massive titanium sublimation pumping to provide the necessary pumping speed and capacity. Operating experience over the last two years has shown that this method of pumping is efficient and inexpensive.

1. INTRODUCTION.

Lost particles generated by the 5.3 GeV e^\pm beams in the collider CESR interacting with the residual gas are a major source of background in the CLEO High Energy Physics detector. They could also lead to radiation damage of sensitive components such as the new Silicon Vertex Detector (SVX) electronics installed around a two-centimeter radius thin beryllium beam-pipe.[1]

An aggressive R&D program to increase the luminosity of CESR has led to successive upgrades of the storage ring, which is now producing peak luminosities of $4 \times 10^{32} \text{ cm}^{-2} \text{ s}^{-1}$ at a beam energy of 5.3 GeV, well beyond its original design specification. The main objective of the 1995 upgrade to Phase-II was to allow storage of up to 300 mA per beam. Increased current produces increased desorption of gases by synchrotron radiation (SR), so that the beam-gas background in the detector could increase proportional to the *square* of the current if the pressure were allowed to increase in proportion. The detector at the interaction point (IP) is most sensitive (in the present optics) to lost particles produced by beam-gas bremsstrahlung in the region up to about 30 m from the IP. The region up to 12 m was in particular need of increased pumping, to keep the pressure below about 2 ntorr at 300 mA.

For Phase-II, the vacuum chambers from the IP up to 12 m were replaced by new chambers, most of them incorporating massive titanium sublimation pumping (TiSP) plenums. The secret to maintaining high distributed pumping speed is, of course, large conductance to the pumping surfaces. The SR fans are

absorbed on water-cooled copper bars and high-conductance slots lead to the pumping surfaces lining the plenum in each chamber. Right after flashing fresh Ti, the sticking coefficient is about 0.7 for CO. The net pumping speed is dominated by the slot conductance and gradually decreases as the Ti surface saturates. The TiSP speed is quite appreciable even when the sticking coefficient has fallen to 0.1. However, we flash again when the operating pressure with beams is about 2 ntorr.

There is another factor that affects the dynamic pressure rise and the flashing interval. It is well known[2] that the SR induced desorption coefficient η_{SR} decreases steadily from its initial high value after intervention. Thus the dynamic pressure rise, dP/dI , expressed in ntorr per mA of beam, continues to decrease with beam dose D , expressed in Amp-hours and correspondingly, the flashing interval increases steadily. Eventually, we find that η_{SR} levels off due to the overall equilibrium between desorption and readsorption of the molecules on the cleaned surfaces during steady operation at a particular beam current. This particular phenomenon has also been observed directly as “wall-pumping”, contributing very significant distributed pumping in regions of intense SR flux.

The variation in desorption yield at any given location is well described by a power law $\eta_{\text{SR}} = \eta_{\text{in}} D^\alpha$, with α of order -1 . The initial yield, η_{in} , immediately after start up of the accelerator can be as high as 0.1 molecule/photon and η_{SR} reaches values as low as 2×10^{-6} mol/photon after exposure to 10^{24} photons/m.

2. CHAMBERS NEAR THE INTERACTION REGION.

Immediately surrounding the IP is a 50 cm long, 2 cm radius double-walled thin beryllium beam-pipe. A silicon vertex detector, the most sensitive part of the detector, surrounds this pipe.

The first pump is the Q1 pump at 2.3 m from the IP. [Figure 1](#) shows two views of the cross-section. The tapered, slotted beam-pipe incorporates water-cooled copper absorber bars in the horizontal plane and is surrounded by a 20 cm radius plenum. The total conductance of the slots leading to the plenum is 620 l/s for N_2 . Three Ti-sublimation cartridges, each with three filaments, are installed on demountable conflat flanges, baffled from each other and from direct line-of-sight to the beam tube. The next pump is a 220 l/s “noble-diode” sputter-ion pump (SIP) at 6 m. This serves to keep the partial pressure of noble gases

* Work Supported by the National Science Foundation

† Presented at PAC'97, Vancouver, B.C., May 1997

and methane in control. It should be remarked here that although there is methane desorbed by the beam, the intense photon and electron flux is efficient at cracking methane (CH_4) to CH_3 and H which are then pumped by the TiSP, so that no buildup of CH_4 is observed.

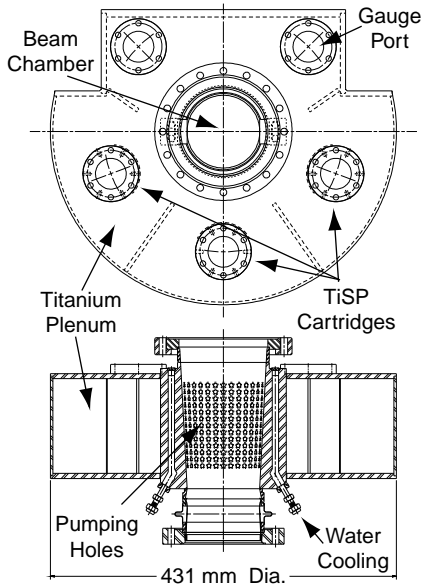

Figure 1. The Q1 titanium pump chamber. Above, view along beam. Below, cross-section looking down.

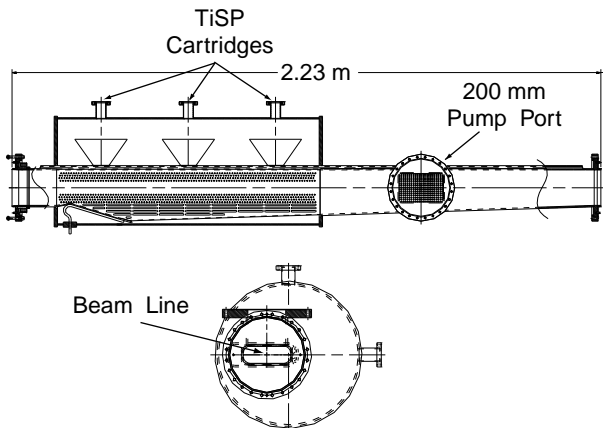

Figure 2. The ISP Chamber with Ti pumping plenum.

Figure 2 shows the “ISP chamber” which occupies the region from 6.4 m to about 8.6 m. From the end nearest the IP, it consists of a section of 1 m long copper beam chamber with pumping slots and holes surrounded by a cylindrical pumping plenum of 0.4 m diameter. This is followed by a 1 m long section of tapered stainless steel chamber, of rectangular cross section. The two sections share a 2.1 m long water cooled copper absorber bar on one side which absorbs SR from the outgoing beam. A separate short 0.3 m long angled water-cooled absorber is on the opposite side to absorb the more intense flux from the incoming beam. The 1 m long pumping plenum has three Ti-filament cartridges. A total surface area of about 10,000 cm^2 is covered by Ti during flashing. The total

conductance of the pumping slots and holes between the beam-chamber and the pumping plenum is about 9,000 l/s . A CCG is installed on top of the pumping plenum. A 204 mm diameter port for an additional 500 l/s sputter-ion pump is located on the tapered part of the SS chamber.

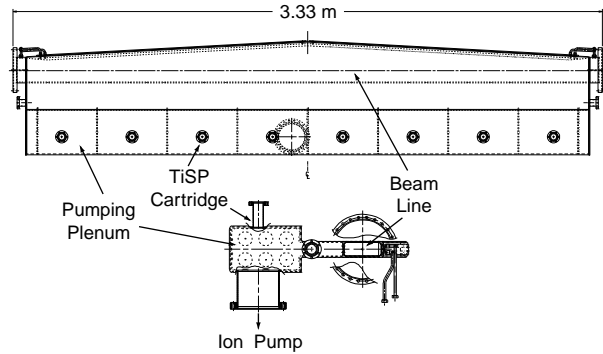

Figure 3. The Soft-Bend Chamber. Top view (above) and cross-section showing Ti pumping plenum.

Figure 3 shows the 3.3 m long “Soft-Bend” vacuum chamber, which is inserted in the first bend magnet of $\rho=140$ m bend radius. This chamber sees the intense SR radiated by the incoming beam in the high field “Hard Bend” (HB) magnets of $\rho=33$ m upstream. The absorber is a 3.2 m long copper bar bent to a chevron shape, with wedge-shaped absorbing steps, designed to prevent reflected SR photons from reaching the sensitive region of the IP. The wedges also serve to concentrate the SR flux resulting in faster clean-up due to increased photon dose per Amp-hour of beam. Two flat stainless-steel plates serve as top and bottom of the beam chamber, leading to a large rectangular copper pumping plenum, 15 cm high by 25 cm wide running the full length of the chamber. Nine vertical baffles give rigidity and increase the surface covered by titanium. A slotted wall of about 7,800 l/s conductance separates the rectangular beam chamber from the pumping plenum. A total surface of approximately 25,000 cm^2 on the pumping plenum and the baffles is covered by Ti during flashing. Eight Ti-filament cartridges are equally spaced in the pumping plenum. A 110 l/s noble-diode sputter-ion pump is mounted on the bottom of the pumping plenum. A CCG is installed on the pumping plenum near the beam line.

TABLE I. Synchrotron Radiation Flux and Gas Load in the CESR IR for 300 mA e^\pm Stored Beams.

Location	Flux Density (Photon/s/m)	Total Flux (Photons/s)	CO GasLoad [Torr-l/s]
Q1-Pump	$1.3 \cdot 10^{18}$	$2.5 \cdot 10^{17}$	$7.9 \cdot 10^{-8}$
ISP absorb.	$1.1 \cdot 10^{19}$	$1.9 \cdot 10^{18}$	$2.0 \cdot 10^{-7}$
Soft-Bend	$3.3 \cdot 10^{18}$	$3.5 \cdot 10^{18}$	$6.7 \cdot 10^{-7}$
Hard-Bend	$6.9 \cdot 10^{18}$	$2.3 \cdot 10^{19}$	$1.3 \cdot 10^{-6}$

An estimate of the CO gas load obtained when the photodesorption yield in the HB region of most

intense flux gets down to $\eta_0 = 1.8 \cdot 10^{-6}$ mol/photon is given in the last column of **Table 1**, which lists typical linear SR flux, total flux and gasloads in different regions of the IR. We use this ultimate value of η_{SR} to predict the vacuum performance of CESR when the vacuum system is fully conditioned, and it is used to model pressure profiles below.

3. MEASUREMENTS OF PUMPING SPEED AND CAPACITY.

Each pumping chamber, after fabrication, was subjected to the following procedures in the laboratory, before installation in CESR: leak check followed by bakeout for 24 hours at 150°C minimum; degassing of all Ti filaments and gauges; saturation of the bare walls with either CO or N₂ using calibrated leaks; flashing of successive Ti cartridges and measurement of base pressures; slow saturation of the Ti surface using CO and/or N₂ calibrated leaks with continuous monitoring of pressure and gas composition. The effective pumping speeds at each stage was determined from the data. A fresh 110 l/s ion pump was attached to the apparatus, in order to keep inert gas partial pressures under control. However, the position of the installed leak at one end of the long chambers did not quite represent the final configuration of beam-induced gas sources in CESR.

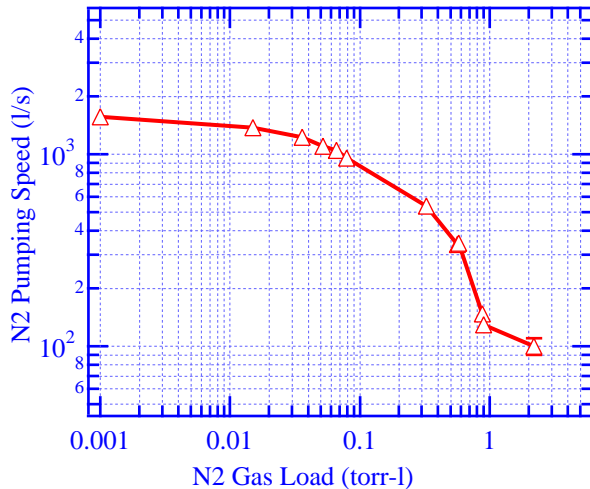

Figure 4. N₂ Pumping Speed, Soft-Bend Chamber.

The experience obtained with the Soft-Bend chamber is quite illustrative and typical. After bakeout and degassing of filaments, initial pumping speeds of the *bare walls* were $S_{N_2} = 957$ l/s and $S_{CO} = 4,400$ l/s ! Significant partial pressure peaks of CH₃, CH₄ and Argon showed clear evidence of passive gettering action. The bare chamber walls absorbed a dose of 0.29 torr-liter of nitrogen. After flashing all eight Ti -cartridges for 2 minutes each at 220 W, the pumping speeds for CO and N₂ were measured as a function of N₂ load. Initial pumping speeds at zero load were: $S_{N_2} = 1,571$ l/s and

$S_{CO} = 8,420$ l/s . This ratio is representative of the much higher initial sticking coefficient for CO, as well as the fact that two Ti atoms are required per N₂ molecule and only one per CO molecule. **Figure 4** shows the N₂ pumping speed versus nitrogen load. After absorbing 2.2 torr-liters of N₂ the CO pumping speed was still as high as 3,500 l/s and decreased to 1,500 l/s after 0.4 torr-liter of CO was absorbed. We did not have the time to saturate the Ti with CO with the 2.2×10^{-6} torr-l/s gas-leak available.

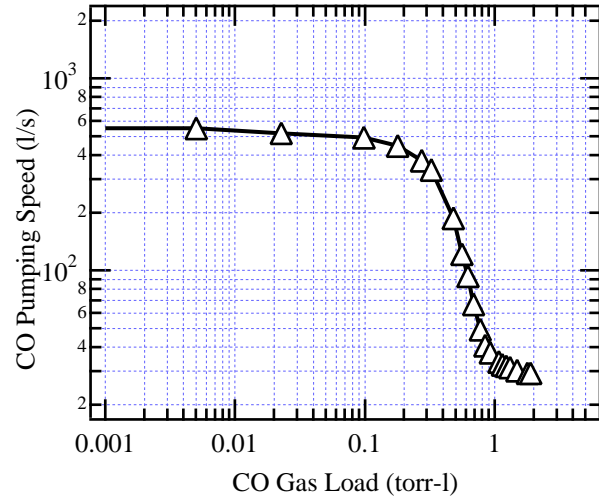

Figure 5. Pumping Speed in the Q1 TiSP chamber.

Figure 5 shows the saturation of the Q1 pump chamber with a large CO gas-leak of 4.2×10^{-5} torr-l/s. The pumping speed falls by five at about 0.6 torr-l/s. In CESR, this is a region of low SR gasload, 8×10^{-8} torr-l/s with 300 mA beams. This suggests that the ultimate flashing interval for Q1 should be about 90 days.

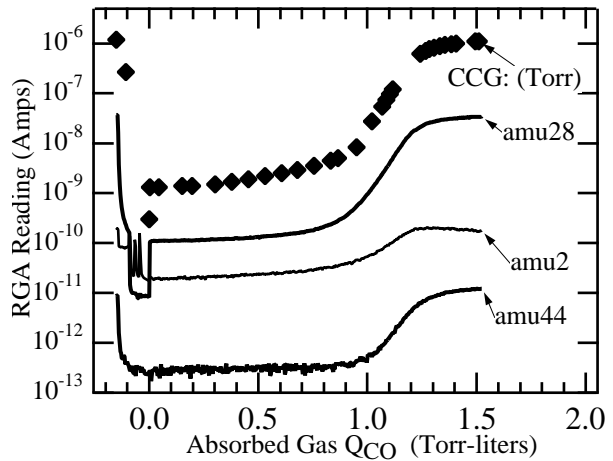

Figure 6. Saturation of the ISP chamber with CO gas. The CCG pressure is on the same axis scale, in Torr.

Figure 6 shows the saturation curves for the ISP chamber using the same large CO gas leak. A turbo

pump (40 l/s effective speed) was used to pump inert gases. Significant saturation of the Ti surface occurs at about 1.0 torr-liters of CO. The ultimate SR-induced gasload at 300 mA per beam is expected to be about 2×10^{-7} torr-l/s, so we expect a flashing interval of about 60 days to maintain pressures below a few nanorr.

4. DYNAMIC PRESSURE RISE IN CESR.

The new IR chambers were installed and CESR operation in PhaseII was started in November 1995. The dynamic pressure rise with beam, (dP/dI), at various locations in the IR is shown in the Figure 7 as a function of beam dose in Amp-hrs. Single beam dose is used where only one beam induces outgassing and total beam dose for chambers where both beams produce a gas load. The points when Ti-flashing occurred are indicated (triangles) and the subsequent points show the slow saturation of the TiSP. The plots include data recorded up to March 3, 1997, representing approximately 14 months of operation, including a few periods of down time.

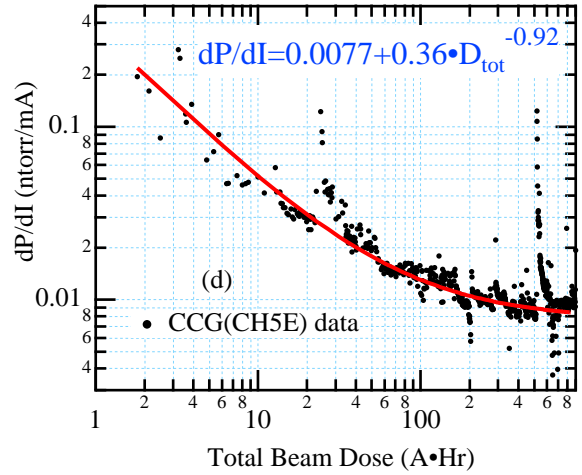
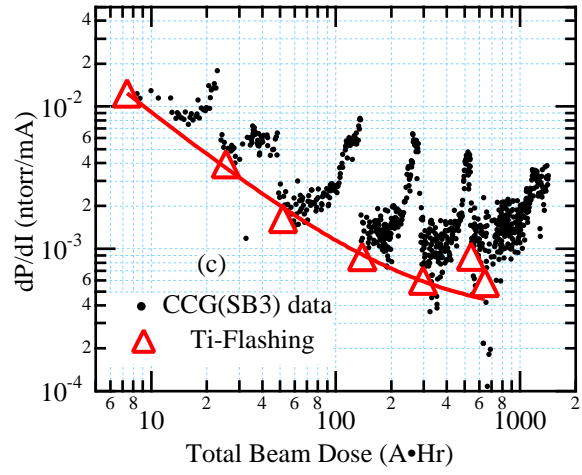
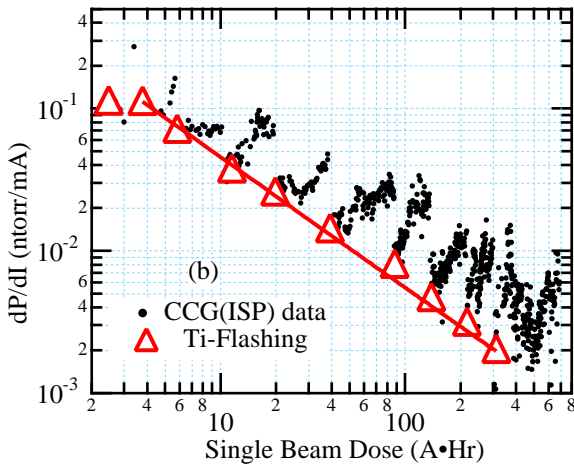
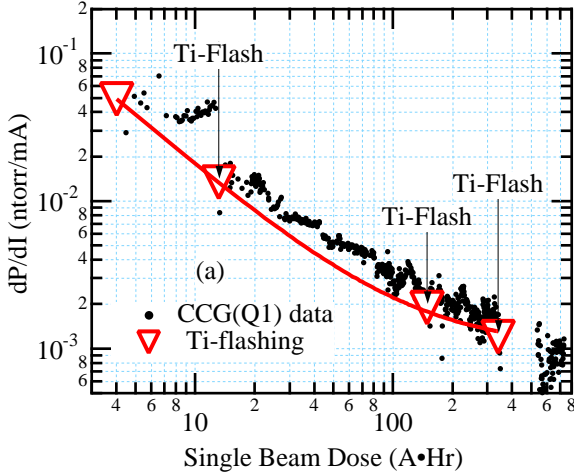

Figure 7. The beam induced dynamic pressure rise, (dP/dI), at various locations in the IR. (a) The dynamic pressure rise at Q1E; (b) a similar plot for a gauge on the beamline next to the ISP chambers, and (c) for the soft-bend chambers. (d) shows a similar plot for a gauge within the hard-bend sector pumped only by distributed ion pumps (DIPs), but where the SR flux and gas load is the most intense.

The clean-up due to the beams is very apparent in all plots and shows the characteristic dose dependence of the gas load, $N_{\text{gas}} = N_{\text{phot}} \cdot (\eta_0 + \varepsilon \eta_{\text{in}} D^\alpha)$, with $\alpha \approx -1$ for all plots. Here ε is the fraction of photons scattered from the primary SR stripe which is assumed to have reached the ultimate low coefficient η_0 . The scattered photons then continue to clean up the rest of the chamber. In the high-intensity HB region (Figure 7d) we see that after about 100 Amp-hrs of total beam, the falling dynamic pressure rise has levelled off to $N_{\text{phot}} \eta_0$. This levelling off indicates the equilibrium between desorption by the beam and readsorption by the cleaned surfaces, leading to a constant effective η_{SR} . The effective desorption level for the different gases is being evaluated from recent spectra.

The excursions from the curve in Figure 7d show the recovery after interventions. The two large

excursions recovered in 35 A-hrs (23 days) and 124 A-hrs respectively. The first was a planned intervention with pure N₂ backfilling. The second was an accident in an x ray beam line, to tunnel air and took much longer to recover.

With the aid of a Monte-Carlo (MC) simulation program[3] we have modeled the vacuum system in the IR, using reasonable estimates for the sticking coefficient of the Ti films and the pumping speed of the noble-diode sputter-ion pumps. Figure 8 shows the calculated profile of the beam induced pressure rise on the beam line, $\Delta P(s)$, and the measured values obtained during an HEP run with 94 mA e^- and 122 mA e^+ , together in CESR.

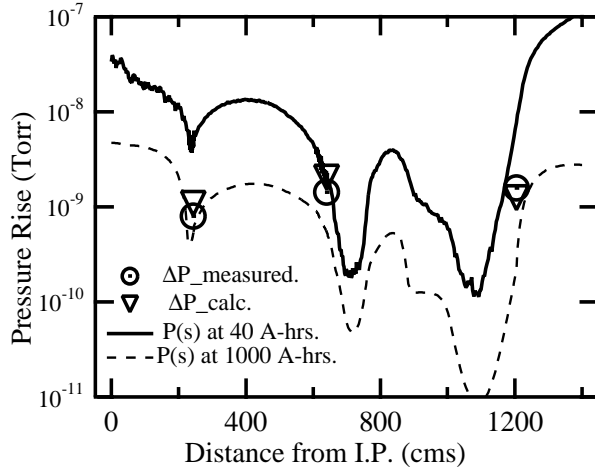

Figure 8: The calculated profile of the beam induced pressure rise on the beam line, $\Delta P(s)$, and the measured values obtained during an HEP run with 94 mA e^- and 122 mA e^+ in CESR. Note that the ΔP measured and calculated for gauges at Q1(at 540 cm) & SoftBend (at 1200 cm) are much lower than the curve as the CCGs are not installed directly on the beam chamber, but rather on the pumping plenums. The solid curve refers to an early stage of conditioning, after a beam dose of 40 Amp-hrs. The dotted pressure profile is for 150 mA e^\pm beams after 1000 A-hrs of running.

5. CONCLUSIONS.

Ti sublimation pumping on an extensive scale has been used successfully in the interaction region of CESR, to keep pressures at a few nantorr level despite the intense SR flux.

Present operation of CESR with two beams of 150 mA each results in operating pressures of between 1.5 ntorr and 3.5 ntorr in most of the IR. This pressure profile is sufficient to keep detector backgrounds at acceptable levels. In the near future, we will install more chambers similar in design to the soft-bend chambers further down the line in the bend region. We expect the pressures to be maintained at the low nanotorr level as the beam currents are raised to 300 mA and beyond.

6. REFERENCES.

- [1] S.Henderson, "The CESR High Luminosity IR", these Proceedings.
- [2] O.Groebner et al., Vacuum **33**, 397 (1983).
- [3] R. Kersevan, "MOLFLOW, a 3D Monte-Carlo Code for the simulation of molecular flow", available from the author, Laboratory of Nuclear Studies, Cornell University, Ithaca, NY, 14853.